

N Male to N Female Adapter

P/N: NMS-ADP-NFS-03

► Specification

www.gigalane.com

Unit : mm [inch]

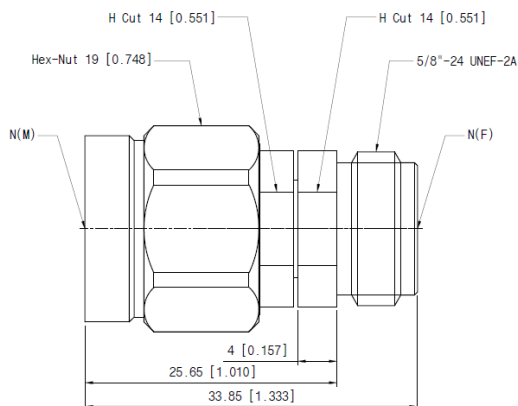

Electrical

Frequency	DC ~ 18 GHz
Impedance	50 Ω
Insertion Loss	IL [dB] = Max. 0.06 X √F
VSWR	DC ~ 18 GHz 1.2:1 max

Materials

Body	Stainless Steel (Passivated)
Center Contact	BeCu (Gold Plated) Brass (Gold Plated)
Insulator	Engineering Plastic

Mechanical

Mating Cycle(Durability)	500
Recommended Mating Torque Proof Torque	0.68 ~ 1.13 Nm / 5 ~12 lbs 1.73 Nm / 15 lbs
Coupling Nut Retention Force	45.8 kgf (450N)
Contact Captivation	2.8 kgf Min. (28N Min.)

Environmental

Temperature	- 40°C to + 125°C
Thermal Shock	MIL-STD-202, Method 107, Condition B
Corrosion (salt Spray)	MIL-STD-202, Method 101, Condition B, 5% salt
Vibration	MIL-STD-202, Method 204, Condition B (20G)
Shock	MIL-STD-202, Method 213, condition I (100G)
Moisture Resistance	MIL-STD-202, Method 106