

SMA Female to SMS Female Adapter

P/N: SFS-ADP-SFS-01

► Specification

www.gigalane.com

Unit : mm [inch]

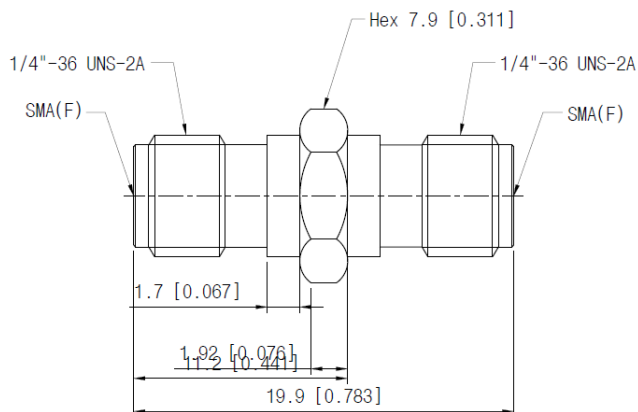

Electrical

Frequency	DC ~ 18 GHz
Impedance	50 Ω
Insertion Loss	IL [dB] = Max. 0.06 X √F
VSWR	DC ~ 18 GHz 1.2:1 max

Materials

Body	Stainless Steel (Passivated)
Center Contact	Beryllium Cooper (Gold Plated)
Insulator	PTFE

Mechanical

Mating Cycle(Durability)	500
Recommended Mating Torque Proof Torque	0.9 ~ 1.13 Nm / 8 ~10 lbs 1.7 Nm / 15 lbs
Coupling Nut Retention Force	270 N / 27.7 kfg / 61 lbs
Center Contact Retention Force	2.6 pound (axial)

Environmental

Temperature	- 40°C to + 125°C
Thermal Shock	MIL-STD-202, Method 107, Condition B
Corrosion (salt Spray)	MIL-STD-202, Method 101, Condition B, 5% salt
Vibration	MIL-STD-202, Method 204, Condition D
Moisture Resistance	MIL-STD-202, Method 106